

# CASIO PT-80

ELECTRONIC MUSICAL INSTRUMENT  
INSTRUMENTO MUSICAL ELECTRONICO

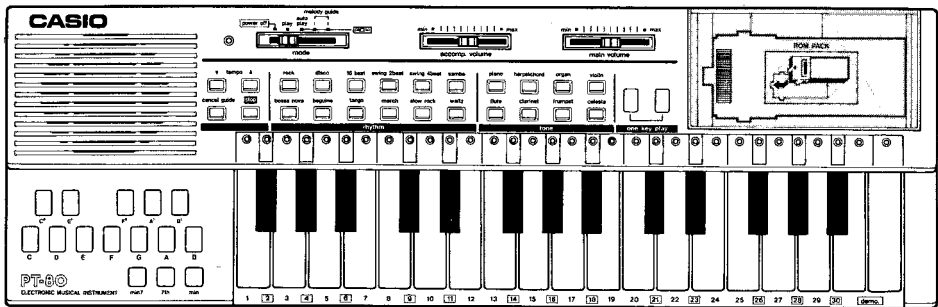

OPERATION MANUAL ..... 1

MANUAL DE OPERACION ..... 25

# **CASIO PT-80**

## **ELECTRONIC MUSICAL INSTRUMENT**

Thank you very much for purchasing the Casio PT-80.  
Before using it, please read this manual carefully in order to  
discover the PT-80's many functions and make full use of  
its potential. For long-lasting enjoyment, please follow the  
directions given here when operating your new PT-80.

## CONTENTS

---

■ Guide to Each Part .....	3
■ Rear Panel (External equipment connection) .....	5
■ Power Supply .....	6
<hr/>	
<b>Part 1 Manual Play</b> .....	<b>8</b>
<hr/>	
■ Starting to play .....	8
■ Selecting a preset sound .....	8
■ Auto-rhythms – 12 lively rhythms to enjoy .....	9
■ Auto-accompaniment – Chord playing made easy .....	10
<hr/>	
<b>Part 2 Memory Play</b> .....	<b>11</b>
<hr/>	
■ Outline of Memory Play .....	11
■ How to install the ROM pack .....	12
■ Auto Play .....	13
■ Melody Guide .....	14
<hr/>	
■ Troubleshooting .....	18
<hr/>	
■ Care of Your Unit .....	19
<hr/>	
■ Specifications .....	20
<hr/>	
★ Casiotone Keyboard Workshop .....	22
<hr/>	
★ Music score .....	48
<hr/>	

# ■ Guide to Each Part

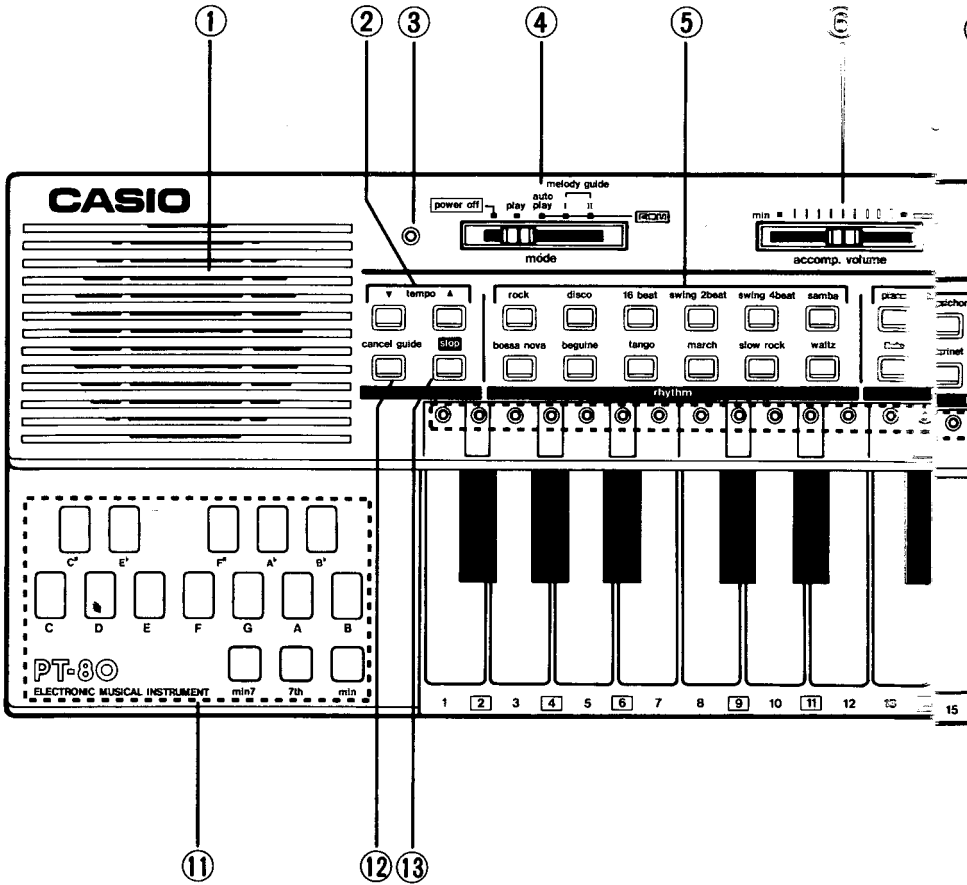

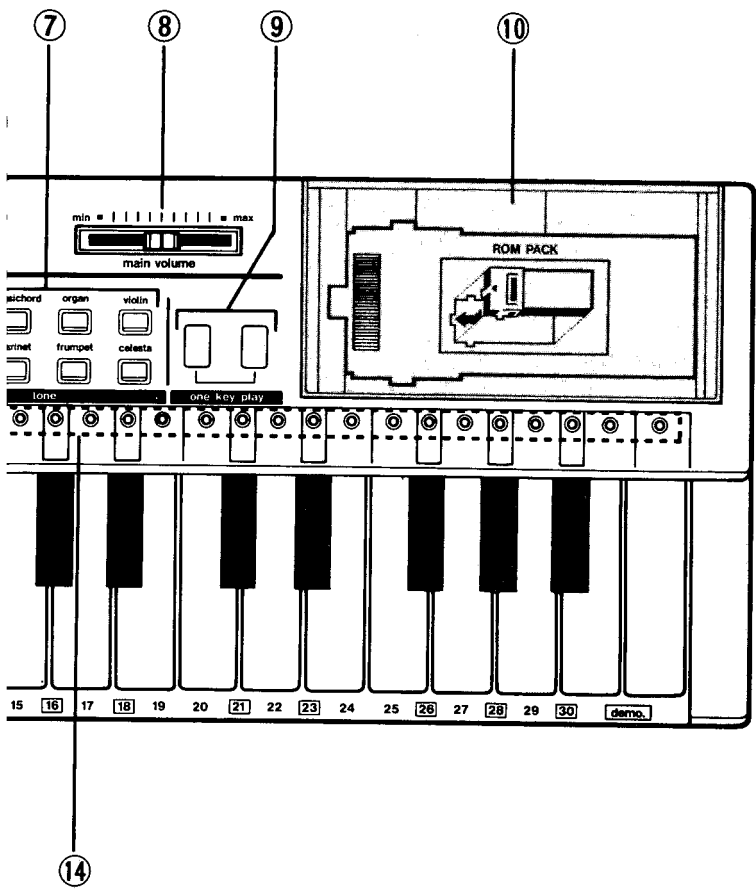

- |                                |                           |
|--------------------------------|---------------------------|
| ① Built-in speaker             | ⑧ Main volume control     |
| ② Tempo control buttons        | ⑨ One key play buttons    |
| ③ Power indicator              | ⑩ ROM pack compartment    |
| ④ Mode selector                | ⑪ Chord selection keys    |
| ⑤ Rhythm selection buttons     | ⑫ Cancel guide button     |
| ⑥ Accompaniment volume control | ⑬ Stop button             |
| ⑦ Sound selection buttons      | ⑭ Melody guide indicators |

## ■ Rear Panel (External equipment connection)

(Rear Panel)

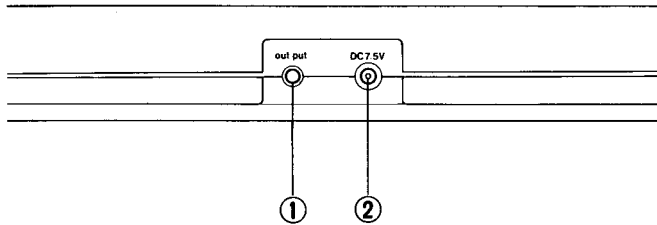

### ① Output jack

If a headphone (mini-plug) is connected, the speaker sound will be cut off automatically and playing can be enjoyed privately. Also, by connecting this jack to audio equipment or a keyboard amplifier, external speaker etc., you can enjoy more powerful volume from the PT-80.

### ② AC Adaptor jack

Plug in the AC adaptor AD-1 (optional) or the car battery adaptor CA-1 (optional). (See page 7)

(Bottom Panel)

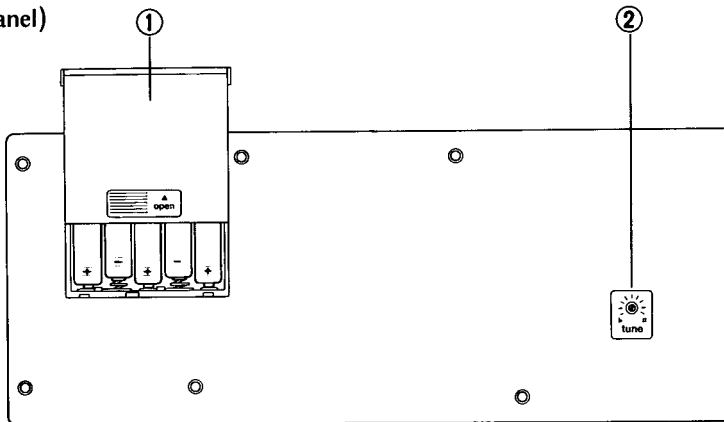

### ① Battery compartment lid

Slide it open and install five AA size manganese dry batteries.

### ② Pitch control

Adjusts the pitch of the entire keyboard within  $\pm 30$  cents and provides easy tuning with other instruments.

\* Be sure to use a standard plastic-grip screwdriver.

## ■ Power Supply

The PT-80 operates on both AC and DC power.

### DC power

- **Dry batteries**

The unit works on five AA size (SUM-3) manganese dry batteries. The lifespan of battery power weakens, sounds may be distorted or the ROM pack memory function may not operate. In this case, replace batteries with new ones.

**Battery installation:**

Open the battery compartment lid on the bottom panel of the unit and install batteries making sure the + and – terminals are aligned correctly.

### Notes on Battery Use

- When replacement becomes necessary, it is advisable to replace all five batteries for longer battery life.
- When batteries are not used for a long period, remove them from the battery compartment to prevent damage from leakage.
- Incorrect use of batteries can lead to fluid leakage or explosion. Please note the following points carefully:
  - ① Please insert the batteries with the poles +, – facing in the right direction.
  - ② Please make sure that all batteries are of the same type.
  - ③ Do not use new batteries and used batteries together.
  - ④ Do not attempt to recharge the batteries.
  - ⑤ Do not dispose of batteries in fire, short-circuit them, open them or heat them.

- **Car battery**

With the optional car battery adaptor CA-1, you can take power from your car battery via a cigarette lighter socket.

## AC power

- To connect the unit to an AC outlet, the AC adaptor AD-1 (optional) is required. Use only an adaptor with the same voltage rating (100, 117, 220 or 240 V) as your power supply to prevent component damage.
- Plug the AC adaptor into an AC outlet and its cord into an AC adaptor jack on the rear panel of the unit.

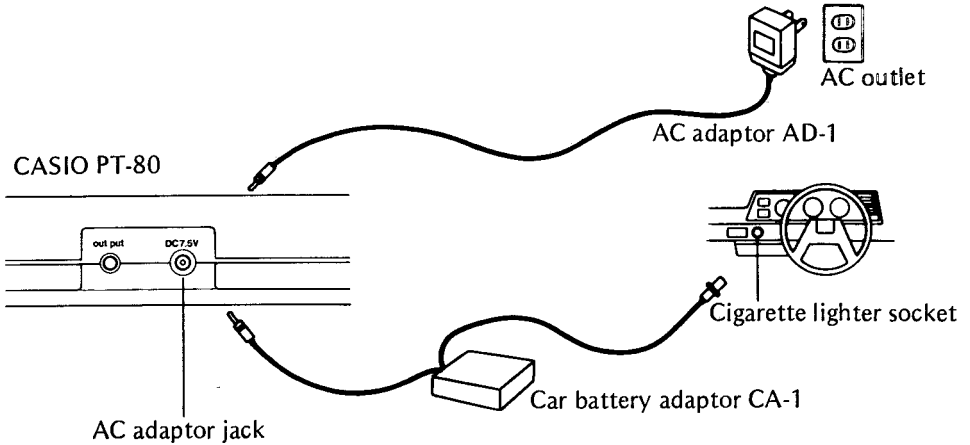

- \* When an AC adaptor or a car battery adaptor is connected to the unit, power supply from the dry batteries is automatically cut off.

## CAUTION

- \* WHEN CONNECTED TO THE MAINS THIS UNIT MUST ONLY BE USED WITH A CASIO MAINS ADAPTOR TO PREVENT THE RISK OF DAMAGE.
- \* When the adaptor is left connected to an AC outlet, it may warm up, but this is quite normal. However, it is advisable to disconnect the adaptor whenever possible, especially if not used for a long time.

### ● Auto power-off function

For power economy, an automatic power cutoff function activates after approximately 8 minutes, if you do not touch the keys. Power supply will be resumed either by pressing the Stop Button or by sliding the Mode Selection Switch to the "off" position and then to another position.

**The following misuse may lead to battery burst.**

1. Use of an AC adaptor other than a genuine Casio adaptor.
2. Insertion of batteries with incorrect polarities (+, -).

# Part 1 Manual Play

## ■ Starting to play

- ① Slide the Mode Selector to “play”.
  - Sliding the Mode Selector from “power off” to any other position switches the main power on. At the same time the melody guide indicators illuminate from left to right in sequence, and the confirmation sound is heard.
  - For manual playing, set the Mode Selector to “play”.
- ② Adjust the volume level.
  - Set the Main Volume Control to an initial position as illustrated.
- ③ Now, start playing.
  - Since the PT-80 is a monophonic instrument, chords cannot be played even if two or more keys are pressed at the same time.

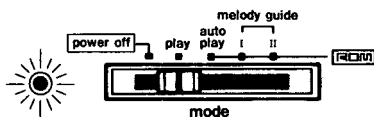

## ■ Selecting a preset sound

Press any one of the Sound Selection Buttons.

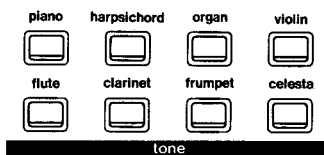

- Sounds cannot be changed if a key is being pressed. Lift your finger from the key and press a Sound Selection Button.
- When the power is turned off, the sound you set will be cleared and the “piano” sound will automatically be selected.

## ■ Auto-rhythms—12 lively rhythms to enjoy

- ① Slide the Mode Selector to “play”.
- ② Adjust the Accompaniment Volume Control to an initial position as illustrated.
  - Accompaniment volume can be adjusted in proportion to the main volume.
- ③ Select a rhythm by pressing one of the Rhythm Selection Buttons.





- The rhythm starts the moment the button is pressed.
- If you want to change to another rhythm, simply press another Rhythm Selection Button.

- ④ Press the Stop Button to stop the rhythm.



### ● Adjusting the rhythm speed

The rhythm speed can be adjusted by two Tempo Control Buttons. Press the  button to speed up the rhythm and the  button to slow the rhythm down.

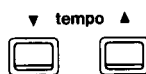

The tempo can be adjusted within a 20-step (1 ~ 20) range.

\* In the initial condition (immediately after switching the power on) the tempo is set to the 15th step ( $\text{♩} = 107$ ).

### ● Fill-in

If you press the Rhythm Selection Button of the rhythm being played, 'fill-in' is accomplished.

# ■ Auto-accompaniment—Chord playing made easy



## ● Mastering chords with selection keys

Chord Selection Keys are divided into two major parts — Root Keys and Variation Keys. By combining these two keys, various chords become easy to play.

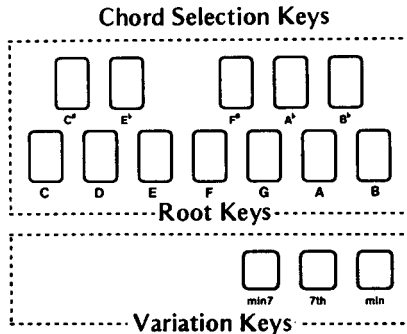
Major chord can be played with a press of a Root Key only. Other chords (min, 7th, min7) are played by pressing a Root Key and a Variation Key at the same time.



Example: C major (C) → Press .

A minor (Am) → Press  and  at the same time.

## ● Playing chords along with the rhythm (Auto-accompaniment)

- ① Slide the Mode Selector to “play”.
- ② Adjust the volume level.
  - Set the Accompaniment Volume Control and the Main Volume Control to an initial position.
- ③ Press one of the Rhythm Selection Buttons and start a rhythm.
- ④ Press the Chord Selection Keys.
  - The chord and bass sounds will be played automatically along with the rhythm.

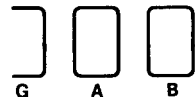

\* Even if your fingers are removed from the keys, the chord will continue until the next key is pressed.

- ⑤ Press the Stop Button to stop Auto-accompaniment.



# Part 2 Memory Play

## ■ Outline of Memory Play

With this memory play function, the melody, chords and obligato stored in the ROM pack can be played back in various ways such as Auto Play, Melody Guide or One Key Play. As shown below, all you have to do is install the ROM pack into the PT-80, choose your playing method and select a tune.

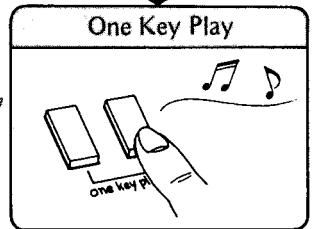
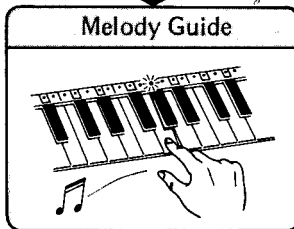
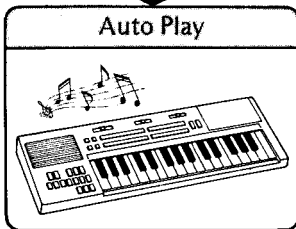
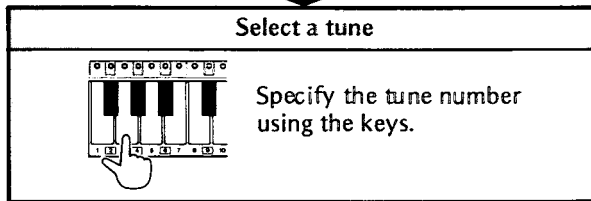
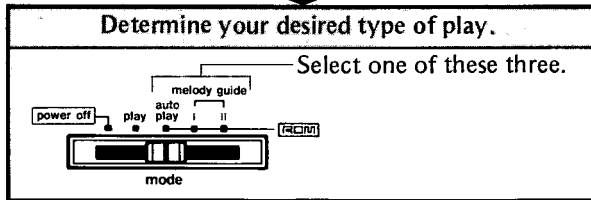
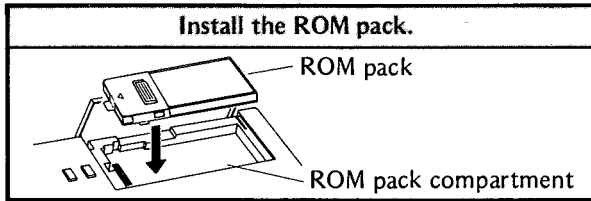

## ■ How to install the ROM pack

- ① Lift up the ROM pack compartment lid on the top panel of the unit.

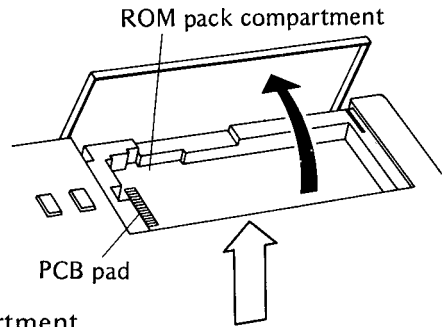

- ② Install the ROM pack into the compartment.
- Place the ROM pack with its connector facing the PCB pad.

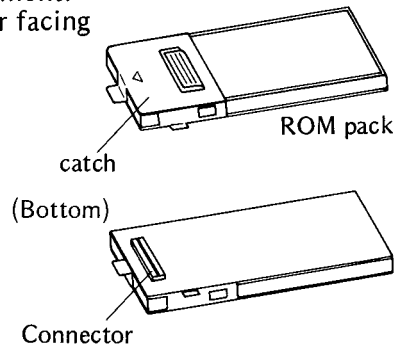

- ③ Fasten the ROM pack by sliding the catch.

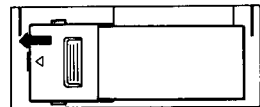

- Since the internal circuitry of the ROM pack may be damaged by static electricity, be sure to ground yourself by touching some metallic object such as a door-knob prior to handling the ROM pack, so as to discharge any static electricity.
- Take good care of the connector part of the ROM pack and the PCB pad of the PT-80. They must be free from dust and dirt, so avoid touching them by hand. Use a soft dampened cloth to clean them.

## ■ Auto Play

Simply by selecting a tune from the ROM pack the PT-80 plays it automatically.

- ① Install the ROM pack into the compartment.

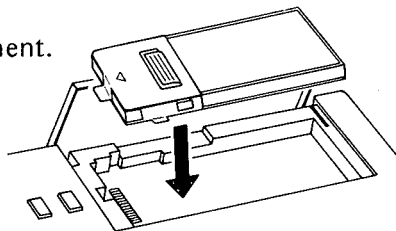

- ② Slide the Mode Selector to "auto play".

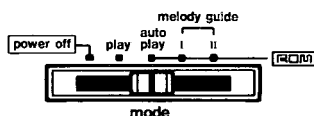

- ③ Select a tune by pressing the keyboard key with the number of the tune you want to hear.

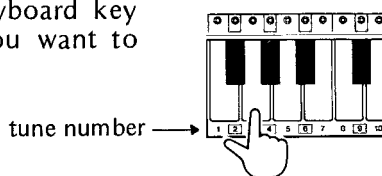

- Auto play starts after a high percussive sound counting the beat for one measure.
- Adjust the volume level using the Main and Accompaniment Volume Controls.
- You can freely change the sound or tempo during auto play.

If you press the top B or C key on the keyboard, all the tunes stored in the ROM pack will be played one after the other endlessly.

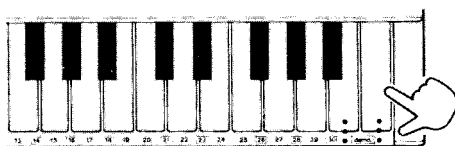

**B C** (demonstration keys)

\* If the ROM pack is not installed in the compartment properly, an "error sound" is heard.

# ■ Melody Guide

The Melody Guide indicators light up in accordance with the stored music and show which key to press. Even a person who cannot read music can play easily by pressing the keys as shown by these indicator lamps. This is ideal for beginners to learn the basics of keyboard playings.

There are two types of Melody Guides, I and II. Here we will start from Melody Guide II.

## 1 Melody Guide II

① Place the ROM pack into the compartment.

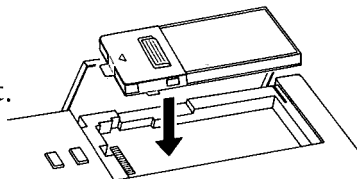

② Set the Mode Selector to “melody guide II”.

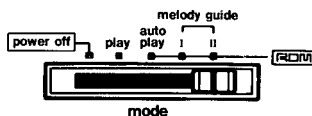

③ Select a tune.

- Melody Guide starts after one measure of beat count.

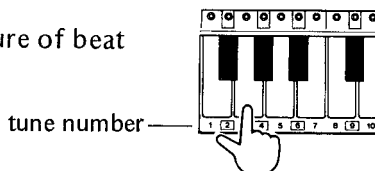

④ Start Melody Guide Play.

- A Melody Guide Indicator lights up and tells you the first key to press.
- Play the first key and then the next key will be shown by a blinking indicator. Play the next key the moment the blinking stops.
- Even if you touch an incorrect key, the lit up indicator waits for you to play the correct one, together with accompaniment and obbligato.
- If the indicator lamp remains on after you play the corresponding key, this means that the same note continues. In this case, press that key again.

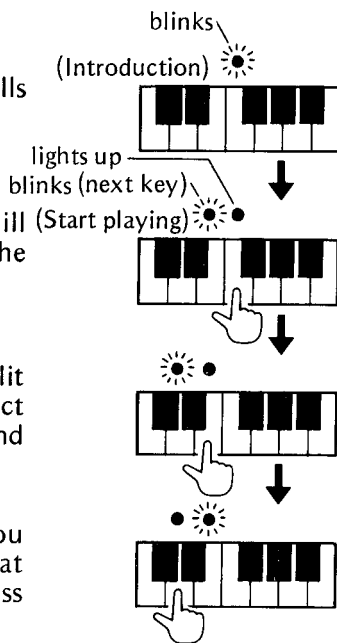

- Press the Stop Button if you want to stop along the way.



### NOTE

Some of the songs start with an introduction and others start without one. Before you start practicing using Melody Guide, listen to the Auto Play carefully and memorize the melody line. Also, if you start playing during an introduction or interlude, that part of the performance will be skipped. (The obbligato part of the skipped introduction or interlude will be played quickly.)

### How to read the Melody Guide Indicator

The Melody Guide of the PT-80 tells you not only the correct keys to press, but also the duration of the note and the next key to play.

① **A key with a lit up indicator**

The key with its indicator lit is the correct key to press. Keep pressing the key until the indicator goes off.

② **A key with a blinking indicator**

A blinking indicator shows the next key to be pressed.

③ **When a note is to be repeated**

The lit up indicator of the pressed key will flicker once. In this case lift your finger once and press the same key again.

④ **When there is a rest**

No indicator will light up during a rest, so there will only be a blinking indicator. Do not play any key until the indicator stops blinking.

## ●Cancel Guide

If you press the Cancel Guide Button (  ) before or during Melody Guide Play, you can cancel the function of the Melody Guide indicators. You can check on how much you have improved. However, if you cannot find the correct key for over 8 beats the Melody Guide indicator will start functioning automatically and show, in sequence, 5 correct keys. The Melody Guide will then be cancelled again.

## 2 Melody Guide I

Accompaniment and the Melody Guide indicator advance in time with the rhythm. They do not wait for you to play the correct key.

① Place the ROM pack into the compartment.

② Set the Mode Selector to “melody guide I”.

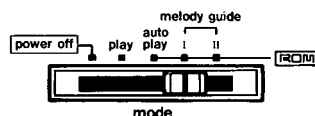

③ Select a tune using the keyboard keys.

- Melody Guide I starts after one measure of beat count. This time, the chords and obbligato proceed without waiting for you.

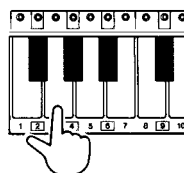

④ The Melody Guide indicators will show you the correct keys to press. Follow the indicators and keep up with the rhythm.

- If the rhythm is too fast, adjust it to an acceptable speed.
- When the music ends, accompaniment and auto-rhythm stops automatically. Press the Stop Button if you want to stop along the way.

## ●Other uses of Melody Guide I

As explained above, when the Mode Selector is set to “melody guide I”, the rhythm, chords and obbligato advance in time with the rhythm, whether you follow the indicators or not. Therefore, you can practice ad-libbing or sing along to the accompaniment.

### 3 One Key Play

Each time a One Key Play Button is pressed, a note of the selected melody can be called out. With this key anyone can enjoy playing simply by using one finger.

① Place the ROM pack into the compartment.

② Set the Mode Selector to “melody guide II”.

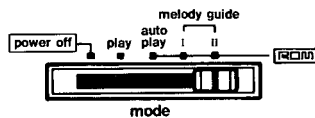

③ Select a tune using the keyboard keys. Wait until an indicator lights up.

\* The operation up to this stage is the same as for the Melody Guide II.

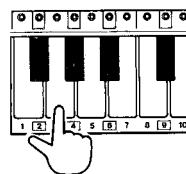

④ Now press either of the One Key Play Buttons and start playing.



- Press the button rhythmically, keeping the melody in mind.
- Either of the two buttons may be pressed, or they may be pressed alternately.
- There is no need to worry about keeping up with the rhythm. If you stop phrasing the melody at a certain location the accompaniment will wait for you to phrase the next melody line.
- The performance stops automatically when the end is reached. But if you want to stop along the way, press the Stop Button.

## ■ Troubleshooting

If you use battery power, make sure that the batteries are not spent.

Symptom	Possible cause	Remedy
No sound is heard when the keys are pressed.	<ol style="list-style-type: none"><li>1. Main volume control is at its minimum.</li><li>2. A headphone is plugged in.</li></ol>	<ol style="list-style-type: none"><li>1. Adjust it to the desired level.</li><li>2. Unplug the headphone.</li></ol>
Preset sound can not be shifted to others.	A Sound Selection button is pressed while a key is being pressed.	Lift your finger from the key and press a Sound Selection button.
Sound is distorted when volume level is too high.	Since the diameter of the built-in speaker is small, it may not reproduce the complete sounds at a high volume level.	Lift your finger from the key and press a Sound Selection button.
No sound is heard when connected to an external speaker.	<ol style="list-style-type: none"><li>1. Main volume control is too low.</li><li>2. The connection cord is bad.</li></ol>	<ol style="list-style-type: none"><li>1. Turn up the main volume.</li><li>2. Replace the connection cord.</li></ol>

---

## ■ Care of Your Unit

---

**① Avoid heat, humidity or direct sunlight.**

Do not overexpose the unit to direct sunlight, place near an air conditioner, or in any extremely hot place.

**② Take care not to drop the unit and avoid strong shocks.**

A strong shock may cause trouble. When carrying or transporting the unit, protect the keyboard and switches with soft materials.

**③ Keep the unit free of liquids, dust, foreign objects etc.**

Do not allow bits and pieces to get between the keys, especially metallic objects such as hairpins, sewing needles or coins. Also, do not wet the unit.

**④ Never attempt to modify any parts of the unit.**

The unit is a precision piece, made up of electronic parts. Any modification of, or tampering with, inner parts may cause trouble or accidents.

**⑤ Do not use a lacquer thinner or similar chemicals for cleaning**

Clean the keyboard with a soft cloth dampened with a mild detergent. (Soak the cloth in a detergent and squeeze until almost dry.)

**⑥ In case of malfunction**

When the unit does not work properly, check whether switches, connections, etc. are set correctly as indicated in the troubleshooting chart on page 18 of this manual. If the unit still doesn't work, please contact the original retailer or a nearby dealer. Never attempt to repair it yourself. It may result in serious damage to components.

## ■ Specifications

<b>Model:</b>	Casio PT-80
<b>Number of keys:</b>	32 keys
<b>Preset sounds:</b>	8 sounds; piano, harpsichord, organ, violin, flute, clarinet, trumpet, celesta.
<b>Auto-rhythm:</b>	12 rhythms; rock, disco, 16 beat, swing II, swing IV, samba, bossa nova, beguine, tango, march, slow rock, waltz.
<b>Auto-accompaniment function:</b>	4 chords; Maj., min., 7th, min 7th.
<b>Memory play function:</b>	<ul style="list-style-type: none"><li>● ROM Pack memory function</li><li>● Auto Play</li><li>● Melody guide I, II, Cancel guide.</li><li>● One Key Play</li></ul>
<b>Pitch control:</b>	within $\pm 30$ cents
<b>Built-in speaker:</b>	6.5 cm ( $2\frac{9}{16}$ " ) dia. x 1 (output = 1.0W)
<b>Output jack:</b>	Output impedance = 50 $\Omega$ Output voltage = 1.6 V (RMS) max.
<b>Power source:</b>	3-Way AC/DC power source; AC: 100, 117, 220 or 240 V ( $\pm 10$ V), 50/60 Hz, with optional AC adapter AD-1. DC: 5 AA size manganese dry batteries. <ul style="list-style-type: none"><li>● Battery life: High performance manganese dry batteries (SUM-3) last about 10 hours.</li></ul> Car battery: Power taken via optional car adapter CA-1.
<b>Power consumption:</b>	1.2 W
<b>Auto power off:</b>	After 8 minutes
<b>Dimensions:</b>	44 (H) x 430 (W) x 140 (D) mm ( $1\frac{3}{4}$ " (H) x $16\frac{15}{16}$ " (W) x $5\frac{1}{2}$ " (D))
<b>Weight:</b>	1.3 kg. (2.9 lbs) including batteries
<b>Standard accessories:</b>	5 AA size manganese dry batteries (SUM-3), ROM pack

*\* Designs and specifications may be subject to change without notice.*

## **GUIDELINES LAID DOWN BY FCC RULES FOR USE OF THE UNIT IN THE U.S.A. (not applicable to other areas).**

This equipment generates and uses radio frequency energy and if not installed and used properly, that is, in strict accordance with the manufacturer's instructions, may cause interference to radio and television reception. It has been type tested and found to comply with the limits for a Class B computing device in accordance with the specifications in Subpart J of Part 15 of FCC Rules, which are designed to provide reasonable protection against such interference in a residential installation. However, there is no guarantee that interference will not occur in a particular installation. If this equipment does cause interference to radio or television reception, which can be determined by turning the equipment off and on, the user is encouraged to try to correct the interference by one or more of the following measures:

- ... reorient the receiving antenna
- ... relocate the computer with respect to the receiver
- ... move the computer away from the receiver
- ... plug the computer into a different outlet so that computer and receiver are on different branch circuits.

If necessary, the user should consult the dealer or an experienced radio/television technician for additional suggestions. The user may find the following booklet prepared by the Federal Communications Commission helpful: "How to Identify and Resolve Radio-TV Interference Problems". This booklet is available from the US Government Printing Office, Washington, D.C., 20402, Stock No.004-000-00345-4.

# Casiotone Keyboard Workshop

Keyboards are generally played using the right hand for the melody and the left hand for the accompaniment. This can be very difficult for beginners. But with PT-80's Melody Guide and Auto-accompaniment function, anybody can learn to play the keyboard quickly and easily. With the "5 Days Step-Up Lesson" you will be amazed at how fast you improve.

## ■ 5 Days Step-Up Lesson

### 1st Day Step 1: Auto Play

- First, listen to the Auto Play and catch the feeling of the tune.

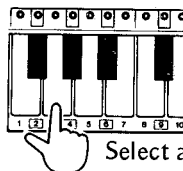
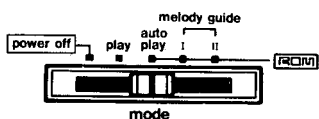

Select a tune.

- Try Auto Play with different preset sound and rhythm.

If you press the top B or C key on the keyboard at tune selection, all the tunes stored in the ROM pack will be played one after the other endlessly.

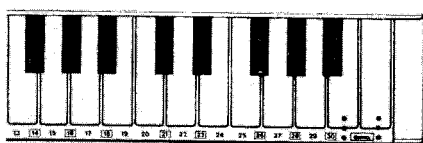

**B C** (demonstration keys)

## 2nd Day Step 2: One Key Play

- Play the melody using the One Key Play buttons and try playing in time with the rhythm.

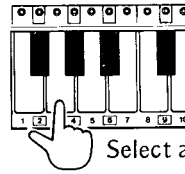
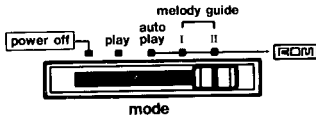

Select a tune.

Even if you lose the beat along the way, accompaniment will wait for you to play correctly.



You can press either of the buttons.

## 3rd Day Step 3: Melody Guide II

Set the Mode Selector to "melody guide II". Keeping the melody in mind, follow the indicator lamps and press the keys. Start with a slow tempo first. Repeat this until you can move your fingers smoothly.

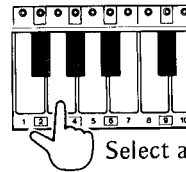
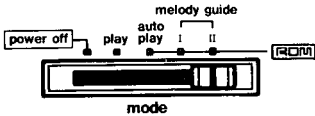

Select a tune.

- The accompaniment will wait for you even if you lose the beat along the way.

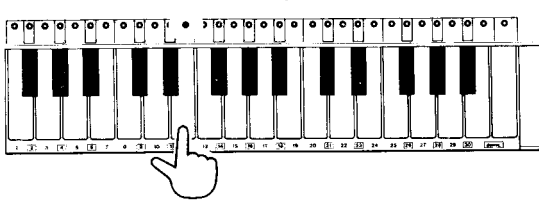

## 4th Day Step 4: Melody Guide I

Play the melody in time with the accompaniment. This time, the accompaniment will not wait for you.

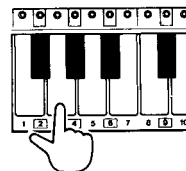
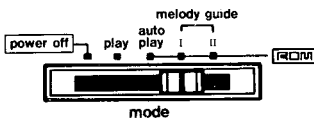

## 5th Day Step 5: Cancel Guide

Have you mastered Melody Guide I and II? Now, cancel the melody guide indicator and play the melody.

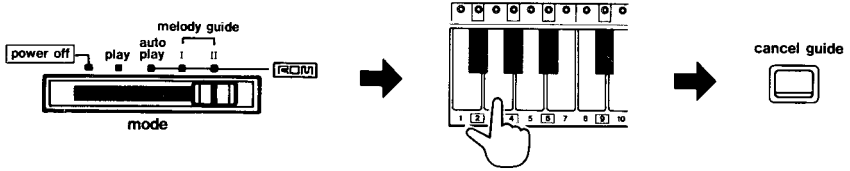

It might be a little difficult at first, but don't worry. If you cannot find the correct key for over 8 beats the Melody Guide indicator will start functioning automatically and show, in sequence, 5 correct keys. The Melody Guide will then be cancelled again.

## Let's try Manual Play

If you have completed the steps 1 through 5, try playing the whole tune by yourself without the aid of the ROM pack memory function.

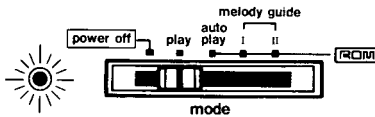

You can easily play the accompaniment with your left hand using the Chord Selection Keys. Auto-accompaniment can be accomplished by starting the Auto-rhythm and pressing the Chord Selection Keys.

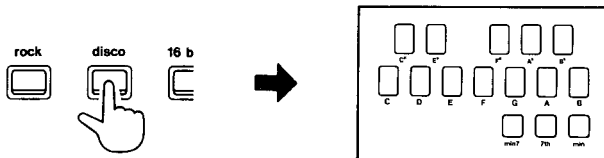

Press the Chord Selection Keys according to the chord progression on the score. After you have mastered playing the left hand part, play it together with the melody, which you play with your right hand.



# ❁❁ MUSIC SCORE/PARTITURA ❁❁

— Before you begin —

- ① The introduction part of the tune are shown in the score. Do not start playing during that part.
- ② The numbers written below the notes show the fingering of the keys.
- ③ Chord names (C, G7 . . .) are written above the lines.

— Antes de comenzar —

- ① La introducción de la melodía se muestra en la partitura. No comience a ejecutar en esa parte.
- ② Los números escritos debajo de las notas le indican como pulsar las teclas.
- ③ La denominación de los acordes (C, G7 . . .) está escrita sobre las líneas.



## 1 // UNTERLANDERS HEIMWEH

1	2
TONE	RHYTHM
FLUTE	MARCH

Musical staff 1: Treble clef, 2/4 time signature. Chords: G7, C, G7, C. Fingering: 1, 2, 1, 2, 2, 3, 4, 5, 4.

Musical staff 2: Treble clef. Chords: C, G7, C, G7, C. Fingering: 3, 3, 2, 2, 1, 1, 2, 1, 2, 2, 3, 4, 5, 4.

Musical staff 3: Treble clef. Chords: C, G7, C, G7. Fingering: 3, 3, 2, 2, 1, 5, 4, 3, 3, 3, 4, 3, 2, 2, 4, 5, 4.

Musical staff 4: Treble clef. Chords: C, G7, C, G7, 1.2.C, 3.C. Fingering: 3, 3, 3, 4, 3, 2, 2, 2, 5, 3, 1, 2, 2, 1, 1, 1.

# 2 // GREENSLEEVES

2	TONE	RHYTHM
	FLUTE	WALTZ

Am

D7

G Em Am D7

G Em Am D7

G Em Am E7 to C

Am C D7

G Em Am7 D

Em C D7

G Em Am E7

Am Coda Am

D.S.

# 3 // DIE LORELEI

TONE	RHYTHM
TRUMPET	WALTZ

C F C F

2 2 3 2 5 4 3 2 1 4

C G C

3 3 2 1 2 3 2

C F C F

2 3 2 5 4 3 2 1 4

C G7 C

3 3 5 4 2 1 3

G Am

2 3 2 5 1 1 5 4 4

G D7 G G7

3 3 2 3 4 3 3 2

C F C Dm C

2 3 2 5 4 3 1 5 4 4 3 3

G7 1.2.C 3.C

2 1 2 3 2 3

# 4 // OLD FOLKS AT HOME

TONE	RHYTHM
TRUMPET ↔ FLUTE	ROCK

Chords: C F C G7 C

Chords: C F C G7

Chords: C F C G7 C

Chords: C F C G7

Chords: C F C G7 C

Chords: G7 C C7 F Ddim (F) G

Chords: C F C G7 C



**CASIO®**